

# RELAY DRIVING BASICS

Relays are components which allow a low-power circuit to switch a relatively high current on and off, or to control signals that must be electrically isolated from the controlling circuit itself. Newcomers to electronics sometimes want to use a relay for this type of application, but are unsure about the details of doing so. Here's a quick rundown.

To make a relay operate, you have to pass a suitable 'pull-in' and 'holding' current (DC) through its energising coil. And generally relay coils are designed to operate from a particular supply voltage — often 12V or 5V, in the case of many of the small relays used for electronics work. In each case the coil has a resistance which will draw the right pull-in and holding currents when it's connected to that supply voltage. So the basic idea is to choose a relay with a coil designed to operate from the supply voltage you're using for your control circuit (and with contacts capable of switching the currents you want to control), and then provide a suitable 'relay driver' circuit so that your low-power circuitry can control the current through the relay's coil. Typically this will be somewhere between 25mA and 70mA.

Often your relay driver can be very simple, using little more than an NPN or PNP transistor to control the coil current. All your low-power circuitry has to do is provide enough base current to turn the transistor on and off, as you can see from diagrams A and B.

In A, NPN transistor Q1 (say a BC337 or BC338) is being used to control a relay (RLY1) with a 12V coil, operating from a +12V supply. Series base resistor R1 is used to set the base current for Q1, so that the transistor is driven into saturation (fully turned on) when the relay is to be energised. That way, the transistor will have minimal voltage drop, and hence dissipate very little power — as well as delivering most of the 12V to the relay coil.

How do you work out the value of R1? It's not hard. Let's say RLY1 needs 50mA of coil current to pull in and hold reliably, and has a resistance of 240Ω so it draws this current from 12V. Our BC337/338 transistor will need enough base current to make sure it remains saturated at this collector current level.

To work this out, we simply make sure that the base current is greater than this collector current divided by the transistor's minimum DC current gain hFE. So as the BC337/338 has a minimum hFE of 100 (at 100mA), we'd need to provide it with at least  $50\text{mA}/100 = 0.5\text{mA}$  of base current.

In practice, you'd give it roughly double this value, say 1mA of base current, just to make sure it does saturate. So if your control signal Vin was switching between 0V and +12V, you'd give R1 a value of say 11kΩ, to provide the 1mA of base current needed to turn on both Q1 and the relay.

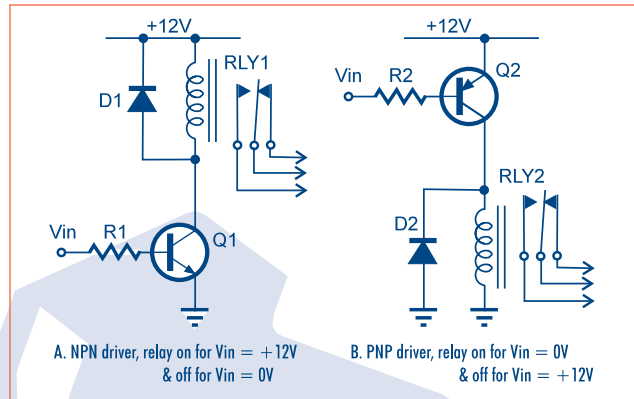

If our relay has a coil resistance of say 180Ω, so that it draws say 67mA at 12V, we'd need to reduce R1 to say 8.2kΩ, to increase the base current to about 1.4mA. Conversely if the relay coil is 360Ω and draws only 33mA, we could increase R1 to 15kΩ, giving about 0.76mA of base current. Each time we go for about twice the relay coil current divided by Q1's hFE — get the idea?

As you can see a power diode D1 (1N4001 or similar) is connected across the relay coil, to protect the transistor from damage due to the back-EMF pulse generated in the relay coil's inductance when Q1 turns off.

The basic NPN circuit in diagram A is fine if you want the relay to energise when your control voltage Vin is **high** (+12V), and be off when Vin is low (0V). But what if you want the opposite? That's where you'd opt for a circuit like that shown in diagram B, using a PNP transistor like the BC327 or BC328. This is essentially the same circuit as in A, just swung around to suit the PNP transistor's polarity.

This time transistor Q2 will turn on and energise the relay when Vin is **low** (0V), and will turn off when Vin is high (+12V). Otherwise everything works just as before, and the value of base resistor R2 is worked out in the same way as for R1. In fact because the minimum hFE of the BC327/328 PNP transistors is also 100 at 100mA, you could use exactly the same values of R2 to suit each relay resistance/current.

The simple transistor driver circuits of A and B are very low in cost, and are generally fine for driving most relays. However there may be occasions, such as when your control circuit is based on CMOS logic, where the base current needed by these circuits is a bit too high.

For these situations the circuit shown in C might be of interest, because it needs rather less input current. As you can see it uses a readily available and very low cost 555 IC as the relay driver, plus only one extra component: bypass capacitor C1.

Although we normally think of the 555 as a timer/oscillator, it's actually very well suited for driving a small relay. Output pin 3 can both source and sink 200mA (enough to handle most small relays comfortably), and the internal flipflop which controls its output stage is triggered swiftly between its two states by internal comparators connected to the two sensing inputs on pins 2 and 6. When these pins are taken to a voltage above 2/3 the supply voltage, the output switches low (0V); then they are taken below 1/3 the supply voltage, the output swings high. And the 555 can happily work at 5V, as you can see, so it's very suitable for driving a 5V relay coil from this supply voltage.

Because the sensing inputs of the 555 are voltage sensing and need only a microamp or so of current, the value of input

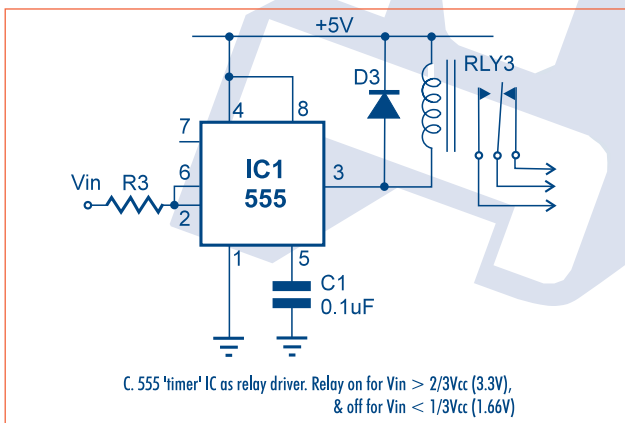

## Jaycar Electronics Reference Data Sheet: RELAYDRV.PDF (2)

resistor R3 can be much larger than for the transistor driver circuits. Typically you'd use a value of say 100kΩ, or even 220kΩ for a circuit operating from 12V.

Although the push-pull output stage of the 555 automatically shunts the relay coil when pin 3 is high, damping the back-EMF, it's probably still a good idea to fit diode D3 as well — especially when using this circuit from a 12V supply. That's because the negative-going back-EMF pulse could cause damage to the transistors inside the 555.

Capacitor C1 is fitted to make sure that the 555 doesn't turn on the relay in response to noise spikes on the supply line.

By the way if you need the very low input current of this

circuit, but want to make the relay operate when Vin is low rather than high, simply connect the relay coil and D3 from pin 3 of the 555 to ground — just like the arrangement shown in diagram B.













Finally in all of these circuits, it's a good idea to fit the supply line of the relay/driver stage with a reasonably high value of bypass capacitor (say 100uF), to absorb the current transients when the relay turns on and off. This will ensure more reliable operation, and help prevent interference with the operation of your control circuitry.

(Copyright © Jaycar Electronics, 2001)

## THE MAJOR INTERNATIONAL TESTING AGENCIES

Most of the developed countries have national testing agencies and certification bodies, which perform testing and issue licences to certify that equipment complies with the electrical safety standards of that country (which are often based on, or derived from international standards).

Some of the main national testing/certification agencies are shown at right, together with the symbols that are used on equipment to certify that it has been tested and complies to their standards.

Germany	VDE		France	LCIE	
Austria	OVE		Netherlands	KEMA	
Belgium	CEBEC		Norway	NEMKO	
Canada	CSA		Sweden	SEMKO	
Denmark	DEMKO		Switzerland	SEV	
Finland	FIMKO		United States	UL	

Australia's standards and certification agency is Standards Australia (SA), of PO Box 1055, Strathfield ([www.standards.org.au](http://www.standards.org.au)). The testing is done by accredited testing laboratories.