

VIDEO SIGNAL FORMATS EXPLAINED

With the development of improved home video equipment in the last few years, there's been a confusing expansion in the variety of video formats you're likely to come across — especially with DVD players, camcorders, laserdisc players and so on. Here's a rundown on the common formats, what they're used for and how they relate to each other.

Composite video

Composite video is the familiar type of 'single cable' video that has been used for many years with home VCRs (both VHS and Beta), camcorders (VHS and Video8), laserdisc players, video CD players, security cameras and so on. This type of video is passed from one piece of equipment to another using a single coaxial or shielded cable, fitted with the familiar 'RCA' or 'phono' plugs (often colour coded yellow).

As the name suggests, composite video has all of the signal components needed to produce a TV image, combined together into a single *composite* signal. This means that the luminance (B&W detail) information, chrominance (colour) information and sync pulses are all combined.

Because it's 'everything in one', composite video is very convenient as a way to transport video information. However because all of the components are lumped in together, it's possible for them to interact with each other if the composite signal is distorted in some way when passing through equipment or being recorded and played back. This can result in various kinds of picture defect: 'colour smear' (colours running outside the boundaries of their correct picture areas), 'dot crawl' or 'Moire' (moving coloured interference patterns in fine picture detail) and so on.

S-video

To try and avoid the picture degradation that can occur with composite video, makers of high-end VCRs, S-VHS and Video Super-8 camcorders and laserdisc players started providing them with a different type of video output and input format. In this *S-video* format (sometimes called S-VHS), the chrominance information is kept separate from the luminance and sync information, to reduce the possibility of interaction.

S-video signals are transferred via *twin* coaxial or shielded cables, which are usually fitted with miniature

4-pin DIN plugs. Sometimes they are fitted with two RCA-type plugs, though, marked 'Y' (for luminance plus sync) and 'C' (for chrominance).

Most video equipment fitted with S-video connectors is also provided with standard composite video connectors, as a 'fall back' option. However if you're using two pieces of equipment which are both able to handle S-video, it's generally better to use their S-video connectors (with a suitable cable) as this will almost always give better picture quality.

This applies particularly with VCRs and camcorders, where the video is actually recorded on tape as separate luminance and chrominance signals. It's less true with

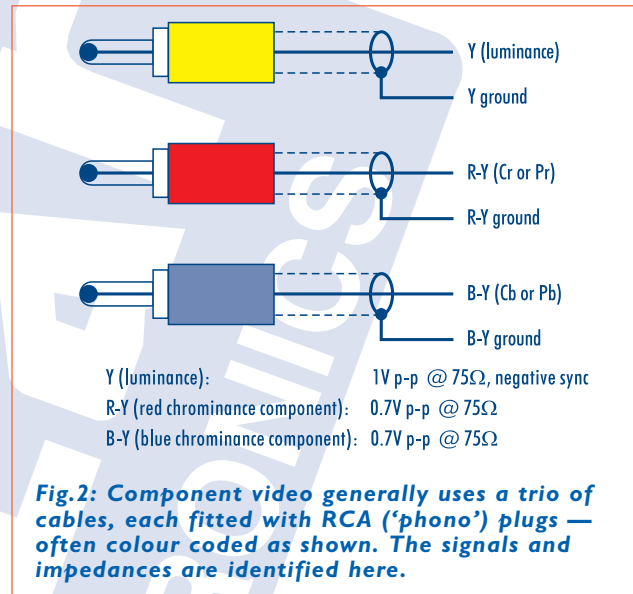

laserdisc players, where the video is in fact recorded on the laserdiscs in composite format. However where a laserdisc player is provided with an S-video output, this will often still give better results than if you use the composite video output — because of the player's more sophisticated Y-C separation circuitry.

Component video

The advent of movies on DVD (digital versatile disc) brought the possibility of delivering even higher image quality. As you're probably aware both the images and sound are recorded on DVDs in compressed digital format, which allows both to be recorded in very high quality. In the case of the images, the original video is separated into *component video* form before being digitised and subjected to MPEG2 compression.

What is component video? It's simply video where the components are separated to an even greater extent than with S-video, so there's even less chance of them interfering with one another.

Instead of simply separating the luminance/sync (Y) and the chrominance (C) information, with component video the chrominance information is further separated into its own two components: the B-Y (blue minus luminance, also called Cb or Pb) and R-Y (red minus luminance, also called Cr or Pr).

So on the latest breed of DVD players, TV receivers and

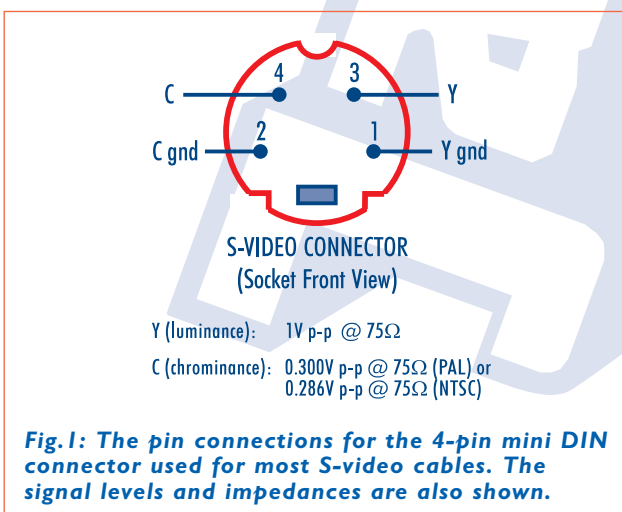

video projectors, you'll find another set of video outputs or inputs: a trio of RCA/phono sockets, generally marked either Y/R-Y/B-Y or Y/Cr/Cb and often coloured yellow, red and blue respectively. Needless to say if the two items of video equipment you need to link together both have these component video connections, you'll generally get the best results of all by using them.

Component video connections are made using a trio of coaxial cables fitted with RCA/phono plugs. Ideally they'll be colour coded to make it easier to avoid transpositions. The two Y sockets need to be linked, and similarly the two R-Y and the two B-Y sockets. You'll get some weird effects if you mix them up!

RGB video

A different kind of component video is found in many of the countries in Europe, where video connections between equipment are often made using multi-way cables fitted with 20-pin SCART connectors (also called Euroconnectors). This type of component video is known as *RGB*, because it consists of the three basic colour components: red (R), green (G) and blue (B). Sometimes the sync information is combined with the green video, and sometimes it's separate again.

Like Y/R-Y/B-Y component video, RGB offers the potential of very high image quality. However the two types of component video are not interchangeable; you can't feed one type directly into equipment inputs designed for the other. Conversion circuitry is needed to change from one to the other.

Note also that just because equipment is fitted with SCART connectors, this doesn't necessarily mean it's capable of handling RGB component video. SCART connectors are actually used to convey all three types of video — composite, S-video and RGB component. To discover which of these formats a piece of equipment can actually handle you'll generally need to refer to its manual.

PAL and NTSC

Most of the video formats we've discussed so far are equally possible with both the PAL video system used in Australia, New Zealand and Europe, and the NTSC system used in North America and Japan. The only real exception is RGB component video, which is found mainly on European equipment using the PAL system.

Needless to say the fact that there's two main video systems introduces a further risk of incompatibility, when you need to connect two pieces of video equipment. Not only do they both need to be capable of handling the same video format, but they also need to be compatible in terms of TV system.

For example although PAL laserdiscs and players were made and sold in both Europe and Australia, they were never as popular as NTSC discs and players sourced directly from the USA. So most of the discs and players you'll find use the NTSC system.

Although most of the TV sets and video projectors sold in countries like Australia and New Zealand over recent years are 'multi standard' and capable of automatically handling either PAL or NTSC, this doesn't apply to many older sets. With these you may need to pass NTSC video from say a laserdisc player through a *standards converter* (to convert it into PAL) before they'll display it properly.

Most DVD players can play discs that were originally in either PAL or NTSC format, providing the discs are compatible in terms of region coding. In many cases they can even play NTSC material in true PAL, or in a hybrid

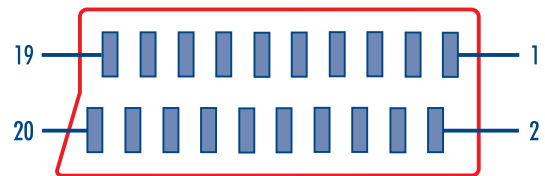

SCART PLUG
(VIEWED FROM PINS)

PIN	SIGNAL	LEVEL, IMPEDANCE
1	Audio Out (R)	500mV @ 1kΩ
2	Audio In (R)	500mV @ 10kΩ
3	Audio Out (L)	500mV @ 1kΩ
4	Audio ground	
5	RGB blue video ground	
6	Audio In (L)	500mV @ 10kΩ
7	RGB Blue Video (B)	700mV p-p @ 75Ω
8	Composite video select	0V/10V @ 10kΩ
9	RGB green ground	
10	Data/Control	
11	RGB Green Video (G)	700mV p-p @ 75Ω
12	Data/Control	
13	RGB red ground	
14	Control ground	
15	RGB Red video (R) / S-video C	700mV p-p @ 75Ω
16	RGB/Composite blanking	<0.4V = comp; >1.0V = RGB
17	Composite video ground	
18	Blanking signal ground	
19	Composite Video out	1.0V p-p @ 75Ω
20	Composite Video in / S-video Y	1.0V p-p @ 75Ω
21	Connector chassis/shield	

Fig.3: The pin connections and signal details for SCART connectors, which can be used for composite, S-video or RGB component video.

standard known as PAL 60 — which retains the field and line scanning rates of NTSC, but with PAL colour encoding.

MPEG1 and MPEG2

There are two main types of image encoding used for the newer media using compressed *digital* video — such as video CDs and DVDs. These are MPEG1 and MPEG2, where 'MPEG' stands for Moving Picture Experts Group (the standards body responsible for developing, agreeing on and approving the digital encoding technology).

MPEG1 was the first type of encoding developed, which compresses the video and audio into a bitstream at a relatively fixed rate of 1.5Mb/s (megabits per second). This is the type of encoding used for video CDs, where it delivers a horizontal image resolution of 352 pixels and a vertical resolution of either 288 pixels (PAL) or 240 pixels (NTSC). This is roughly equivalent to VHS videotape, although some 'blocking' pixilation may be evident when there is a lot of independent fast-moving changes to the image.

MPEG2 is a further development of the digital encoding technology embodied in MPEG1, with additional enhancements and extensions. It is capable of encoding a video-plus-audio bitstream at variable rates up to 15Mb/s, with the video occupying up to 9.8Mb/s. This is capable of delivering very high image quality. MPEG2 encoding is used on DVDs, where it delivers an image resolution of 720 x 576 pixels (H x V) in PAL and 720 x 480 pixels in NTSC — roughly double that of MPEG1 in both directions, and significantly better than the analog video from laserdiscs.

Most DVD players can decode both MPEG1 and MPEG2, and can therefore play either DVDs or video CDs (as well as audio CDs). However earlier dedicated video

CD players can generally only decode MPEG1.

IEEE-1394

Sometimes called *FireWire* (although this term is copyright by Apple Computer), IEEE-1394 is a high speed serial digital interfacing standard used to transfer *digital* video signals from one piece of equipment to another. It can transmit at data rates of up to 400Mb/s, although interfaces on current digital video camcorders and VCRs are only capable of rates up to 200Mb/s. This is clearly more than enough to handle MPEG1 or MPEG2 compressed digital bitstreams, and sufficient for some uncompressed digital video formats.

The digital bitstream transferred via an IEEE-1394 interface is combined with clock signals to form a differential non-return-to-zero (DNRZ) signal, which is sent over a shielded twisted wire pair (TWP). The DNRZ signal consists of complementary 220mV peak to peak rectangular signals superimposed on a

common-mode DC voltage of 1.9V.

A typical IEEE-1394 interface cable may have two shielded TWP cables for bidirectional information transfer, plus two optional additional wires for supply of DC power. This type of cable can convey digital video bitstreams over distances up to about 4.5m.

Some digital camcorder manufacturers, including Sony, call the IEEE-1394 interface 'iLink DV' when it's used for digital video.

Compact six-pin (3 x 2) connectors are used for IEEE-1394 interfaces for computers, digital editing systems and hard disks used for digital video storage etc. However subminiature four-pin (4 x 1) connectors are generally used for IEEE-1394 interfaces on digital camcorders. Adaptor cables are available to connect between the two types of connector.

(Copyright © Jaycar Electronics, 2000)

VIDEO CABLES STOCKED BY JAYCAR

Jaycar Electronics currently stocks a wide range of video interconnecting cables — plus of course audio cables as well.

Included in the range of video cables are single RCA-RCA cables for composite video, 4-pin mini DIN to 4-pin mini DIN cables for S-video, triple RCA-RCA cables which can be used for component video (or composite video plus stereo audio), and various cables fitted with SCART plugs — SCART to SCART, SCART to 3 x RCA and SCART to 6 x RCA, and SCART to 4-pin mini DIN plus 2 x RCA (for S-video plus stereo audio).

Many of the cables are available in a variety of lengths, and in either standard quality or premium quality (with OFC cable conductors, metal connector shells and gold-plated connector pins).

For more information on specific cables please refer to the latest edition of the Jaycar Engineering Catalogue, or visit the catalogue section of the Jaycar website at www.jaycar.com.au